

ROTADAIRON®

ED 130 TS

DETHATCHER - COLLECTOR FOR TRACTOR

WEEDING

RAKING

SOIL
PREPARATION

SEEDING

OVERSEEDING

DETHATCHING-
SPIKING

MULCHING



MADE IN FRANCE

DETHATCHER - COLLECTOR FOR TRACTOR

ED 130 TS

Functions of the Dethatcher - Collector ED 130 TS

This dethatching / collecting machine allows to carry out the dethatching operations of a green in one pass. The machine has a patented sweeping system with hydraulic drive. The hydraulically discharged collection container, with a capacity of 180 liters, allows for the clearing of a whole green. In addition to these operations, the machine can also be used to aerate the ground (spiking effect, without power take-off) or to roll. The machine is equipped with a quick-change blade system (Rotadairon® patent). The blades are positioned magnetically on their support. All the supports are locked by a single nut at the end of the rotor axis.

Quality of service

A large stock of spare parts is permanently maintained at our factory. Our partners have online tools and quick access to manufacturer information. Maintain the quality and performance of your Rotadairon® by using only original parts.

1 3 knife configurations :

- a Sharpened (standard): Stainless steel knife sharpened for classic de-thatching
- b Not sharpened: Made of stainless steel knives not sharpened for more aggressive de-thatching
- c Carbide plate: Carbon steel with carbide plate for very aggressive de-thatching

2 Magnetic knife positioning (quick change)

3 Unique nut at the end of the rotor shaft

4 Floating 3rd point hitch for better ground following

5 Hydraulic system (Cylinders) for unloading the tank

6 Hydraulic system (Motor) for perfect felt collection

Machine	ED 130 TS
Working width	1300 mm (51" 1/4)
Total width	1840 mm (72" 1/2)
Weight	366 Kg (806.8 lb)
Tractor : Required power	25 - 45 CV
Working depth	0 to 60 mm (0" to 2" 1/4)
Distance between knives	24 mm (15/16")
Rotor outer diameter	360 mm (14" 1/4)
Depth adjustment	Front roller support with 2 marked positions + Rear roller support adjustable by screw jack
Number of flanges	53
Number of knives	159
3 point hitch	Categories 1 & 2
PTO speed	540 tr/min
Tractor forward speed	3 to 8 Km/h (1.8 to 4.9 mph)
Transmission	Angle gearbox + Oil bath chain
Transport dimension w x L x H	1840 mm x 1420 mm x 840 mm (72" 1/2 x 56" x 33")

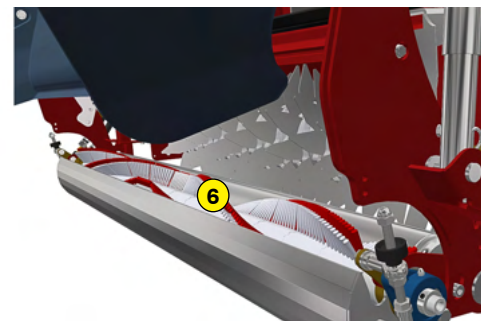
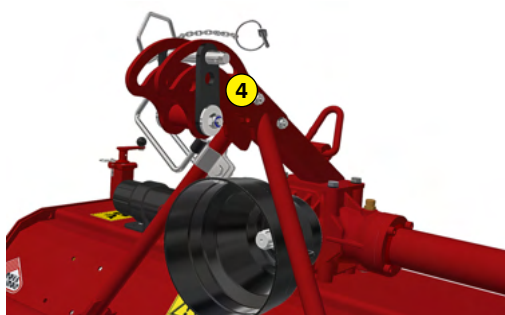
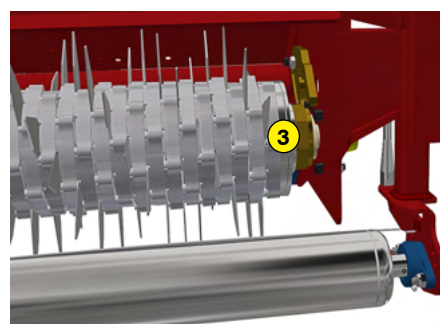
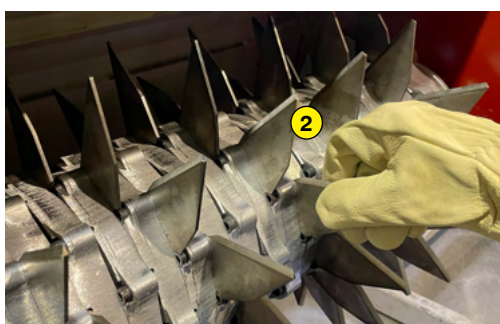
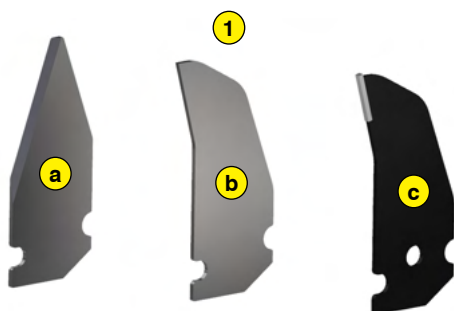

ROTADAIRON
Départementale 92 - Les Hunaudières
72230 Mulsanne - France
Mail : contacts@rotadairon.fr
Phone number : (33) 2 43 422 422



www.rotadairon.fr