

# ROTADAIRON®

# DCE 3000

ROTARY TILLER FOR TRACTORS

SOIL PREPARATION

SEEDING

OVERSEEDING

DETHATCHING  
SPIKING

MULCHING

SPECIAL APPLICATIONS

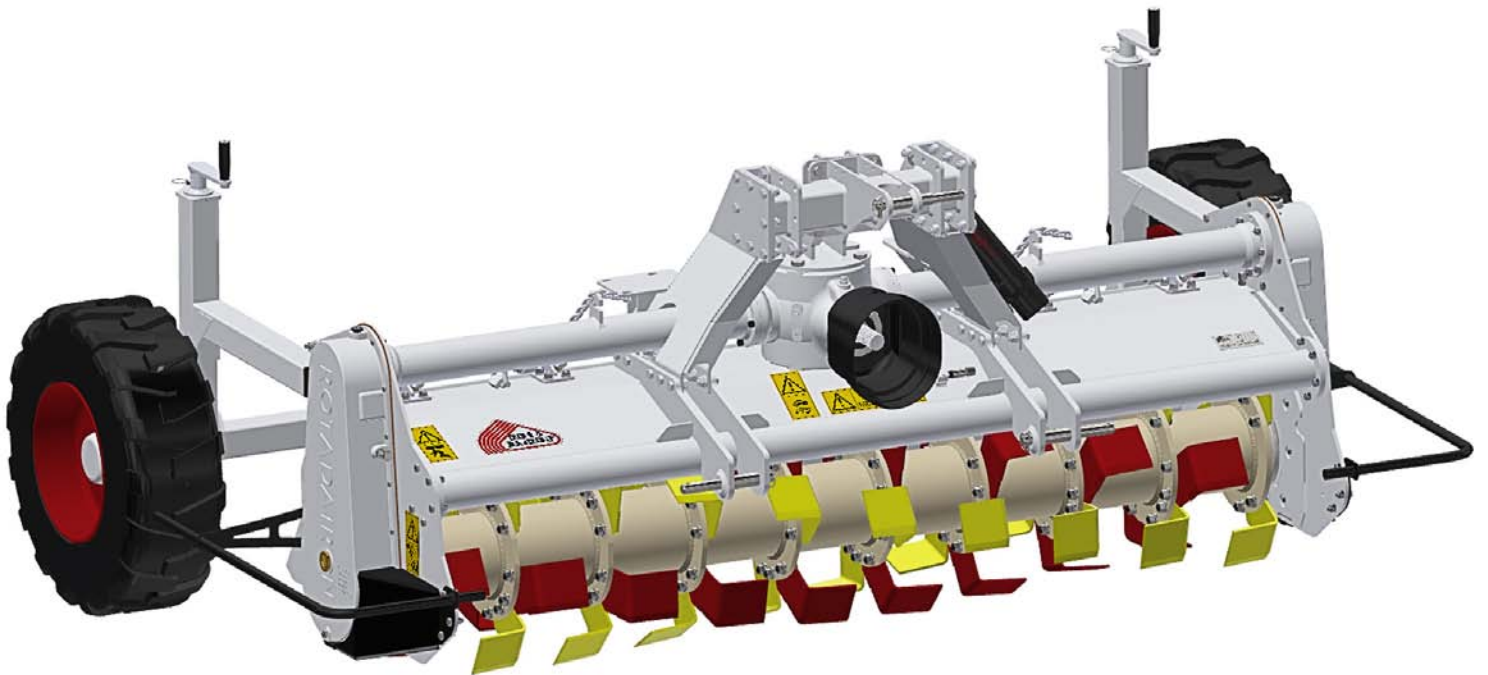

MADE IN FRANCE

# ROTARY TILLER FOR TRACTORS

## DCE 300

### Fonctions of the rotary tiller DCE 300

The Rotadairon® DCE 300 is designed for professional farmers. Its oversized rotor with double drive is designed to fight against the effect of battance, formed under the action of intense rain and trampling.

Equipped with oversized tiller with double drive, the DCE 300 is specially designed for applications in difficult soils.

### Quality of service

A large stock of spare parts is permanently maintained at our factory. Our partners have online tools and quick access to manufacturer information. Maintain the quality and performance of your Rotadairon® by using only original parts.

Machine	DCE 300
Working width	3050 mm (120")
Total width	3920 mm (154" 1/4)
Weight	1470 Kg (3240.7 lb)
Tractor : Required power	110 - 150 CV
Tractor : Max track width	3.05 meters (120")
Working depth (max)	200 mm (7" 3/4)
Rotor outer diameter	600 mm (23" 1/2)
Depth adjustment	Support on Rear tires adjustable by screw jacks
Number of blades	66
3 point hitch	Categories 2 - 3
PTO speed	1000 tr/min
Tractor forward speed	0,8 to 1,5 Km/h (0,5 to 0,9 mph)
Transmission	Angle gearbox + Oil bath chains
Machine drive type	Dual drive
Security	Torque limiter in oil bath at each end of the rotor
Transport dimension w x L x H	3920 mm x 1825 mm x 1275 mm (154" 1/4 x 71" 3/4 x 50" 1/4)

- 1 Oversized rotor
- 2 Blades
- 3 Torque limiter in oil bath at each end of the rotor
- 4 Tiller : principle of operation
- 5 Rear doors adjustable
- 6 Working depth adjustment

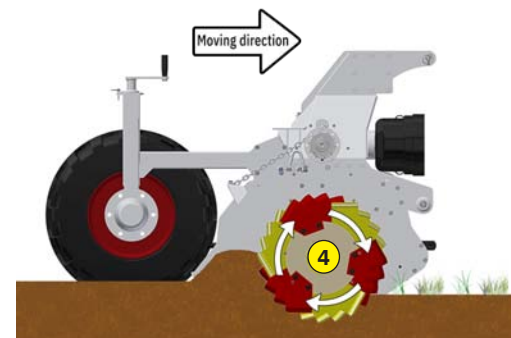
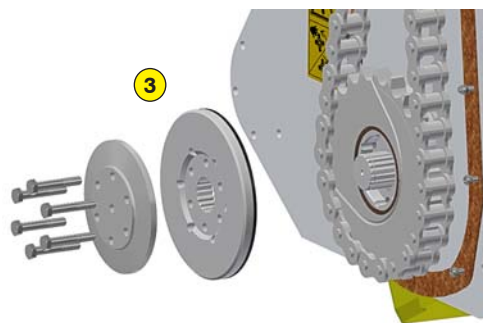
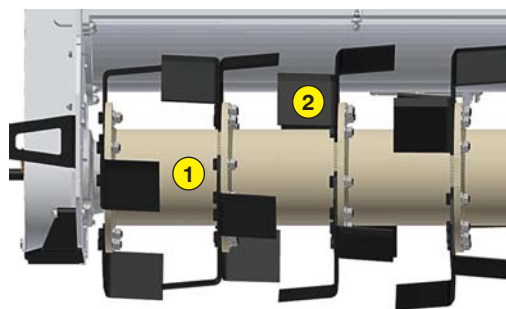

ROTADAIRON  
Départementale 92 - Les Hunaudières  
72230 Mulsanne - France  
Mail : [contacts@rotadairon.fr](mailto:contacts@rotadairon.fr)  
Phone number : (33) 2 43 422 422



[www.rotadairon.fr](http://www.rotadairon.fr)